

Windtech



manual

WINDSOS

Windtech

www.windtech.es

WINDSOS

16 - 18 - 20

instruction manual

> index

> introduction	-----	05
> general description	-----	05
> warning & liability	-----	06
--technical specifications	-----	06
--construction	-----	06
> folding instructions	-----	07
> inspection & repacking	-----	10



> introduction

Congratulations on your purchase of the **Windtech** "Wind-SOS" emergency system.

The advanced design of this emergency parachute allow us to achieve an extremely fast opening time, combined with a smooth and stable decent rate which are the two most important factors in a reserve system.

We have selected the best materials available in the market and developed several innovative solutions in order to improve both performance and longevity of this emergency parachute.

We are proud of our achievement and happy to present you one of the best products available.

> general description

The "Wind-SOS" line of products are round "pull-down-apex" type emergency parachutes, with 16, 18 or 20 gores.

This design provides the most efficient & fastest opening of the parachute and, also, an excellent decent ratio. In addition to the lines attached to the perimeter of the canopy, there is a stronger extra line that pulls down the centre or "apex" of the canopy.

The shape that results from this structural conception requires less volume of air to be filled - fast opening - and, as it is flatter, produces more lift - smooth decent.

> warning & liability

This reserve parachute is an emergency system designed to be used as a last chance to reduce the speed of decent in the event of an emergency during flight. It must be obviously used and controlled by pilots who fully understand the abilities and the limits both of the glider and of the reserve parachute.

The manufacturer and the seller disclaim any liability of the use or misuse of this product, which can result in serious personal injury or death. In using this product the user freely agrees to assume and accept the risk inherent in this sport.

-- technical specifications

windsos	16	18	20
area	31	35	48
gores	16	18	20
central line	5,85	5,85	6,5
bridle	0,4	0,4	1,2
total weight (kg)	<105	<120	<220
weight of system (kg)	2,2	2,6	3,8
sink ratio (m/s)	4,4	4,4	4,7
certification	AFNOR	AFNOR	In process

-- construction

canopy fabric	f111 ripstop nylon or equal material
reinforcements	15mm polyamide bridle
suspension lines	3mm nylon cord - 4mm nylon cord
apex lines	3mm nylon cord - 4mm nylon cord
central line	6mm nylon cord - 8mm nylon cord
bridle	25mm high resistance polyamide bridle

> folding instructions

The folding of the parachute is critical because from a correct folding depends the efficiency of opening when necessary.

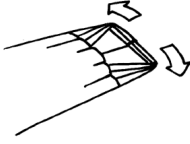

Stretch the parachute completely by holding the lines in each end, the apex and the leading edge.

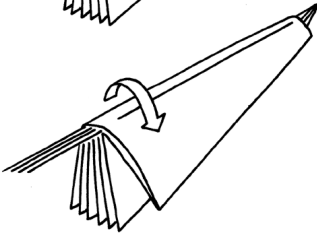
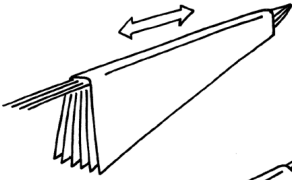

Tidy up each gore, one by one until reaching twice gore number 1.

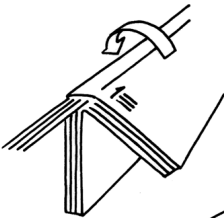
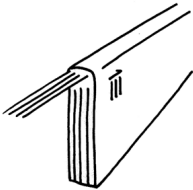

Pass to the other side half of the number of gores of the parachute (16, 18 or 20), one by one, and then lie down and pass back again those gores until you reach gore number 1.

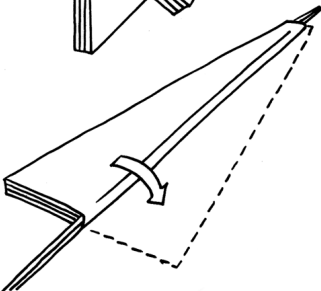

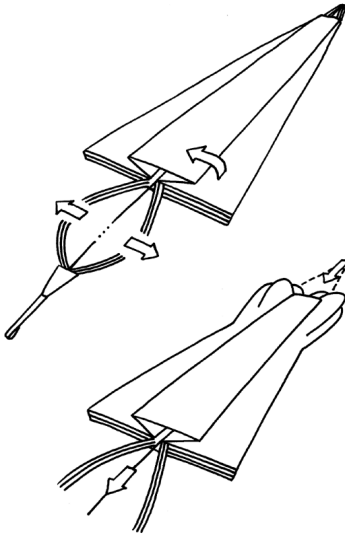

Open in the centre of the canopy gore number 1. Separate and untangle both line groups, left and right from the central line.

Pull the central line and help the canopy to enter into himself in the apex side until all the lines, including the central one, are stretched.

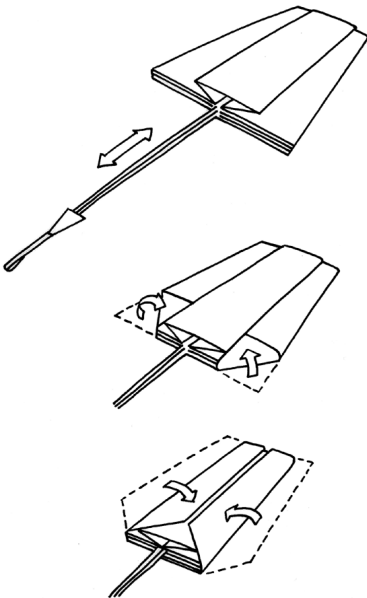

Fold the corners of the canopy, then both sides into the centre and in the last fold open inside gore number 1.

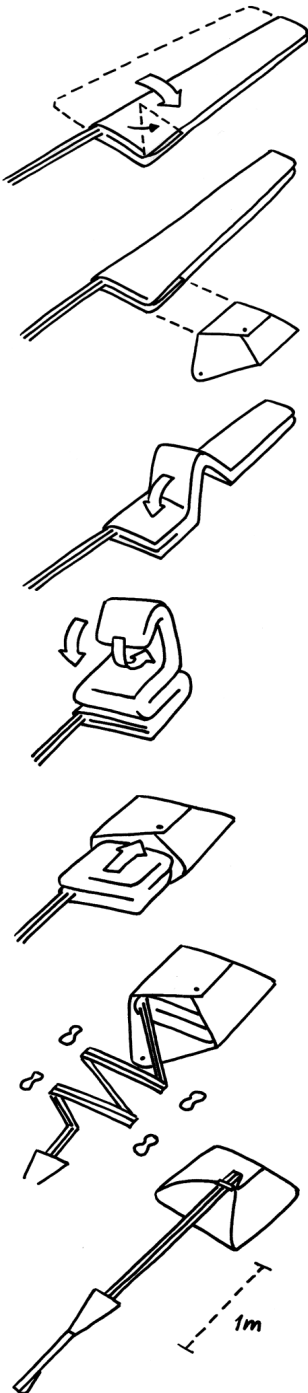

Fold the parachute like an accordion with each fold roughly corresponding to the internal bag size. The last fold should be to the inside. Put the canopy in the internal bag and close it with the hand strap temporarily.

Fold the lines in two figure of eight shape sections to the size of the internal bag and approximately of the line length. Put a rubber band over each end of line section and finely close the internal bag with a line loop.

Note

The reserve handle should be attached to the internal bag and the parachute bridle should be attached to the harness by an appropriated carabiner.

> **Windtech** team

WINDSOS

Windtech

francisco rodríguez · 7	33201 g i j ó n	spain	p.o. box · 269 33280
p# · 34 985 357 696	fax · 34 985 340 778		
email · info@windtech.es	web · www.windtech.es		



POWERED BY WINDTECH